

- *Sensors*
- *Monitors*
- *Analyzers*



“Experts in Oxygen Analysis”

6526 South Cottonwood Street

Salt Lake City, Utah 84107

Tele: (801) 266-5300 FAX: (801) 270-5590

Toll Free in the U.S.: (800) 748-5355

visit us at
www.maxtecinc.com



HANDI™+ Oxygen Analyzer
Industrial Version

Operating Manual

MANUAL Part # R218M15 Rev. A
HANDI™+ Part # R218P15

Maxtec, Inc.

6526 South Cottonwood Street

Salt Lake City, Utah 84107

Tele: (801) 266-5300 FAX: (801) 270-5590

Toll Free in the U.S.: (800) 748-5355

www.maxtecinc.com

Index

Warranty Policy	Page 2
General Specifications	Page 3
Introduction	Page 4
Intended Use	Page 4
For Your Safety	Page 4
Operation	Page 6
General	Page 6
High Pressure Port	Page 7
Calibration	Page 8
Calibration Errors and Codes	Page 9
Maintenance and Disposal	Page 10
Ordering Information	Page 11

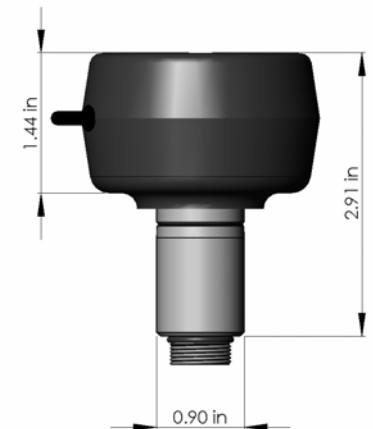

Warranty Policy

Maxtec® warrants to the original purchaser, that the HANDI™+ analyzer to be free from defects in material and workmanship for a period of two-(2) years from the date of shipment from Maxtec® or from one of Maxtec®'s authorized dealers. Parts found to be defective as determined by Maxtec®, will be repaired or replaced free of charge if shipped prepaid to the factory in the original shipping carton. This warranty is void if the product has been subject to misuse or abuse, including but not limited to: exposure to water, humidity- temperature- shock or pressure outside of the listed specifications, or has not been operated in accordance with instructions, or if the identifying markings on the product label have been altered or removed. Routine maintenance items are excluded from this warranty.

The seller assumes no liability for consequential damages of any kind, and the buyer, by acceptance through purchase of this product, will assume all liability for the consequences of its use or misuse by the buyer, his employees, or others.

It is the sole responsibility of the buyer / user to determine if this product is suitable for the intended application.

Ordering Information

Description Part Number

Industrial HANDI™+	R218P15
Barbed Adapter	R207P17
Manual	R218M15
Clear Tube	R100P92-002
Lanyard	R213P92
MaxBox "Otter"	R213P90
Handi™+ Cover	R218P09

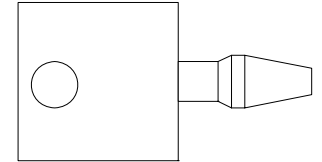

Accessories:

Flow Diverter Fitting
(for use with medical tee):
#R110P10

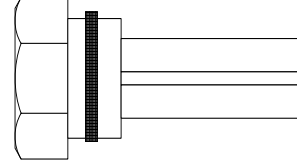

Standard BC Adaptor: #RP11P28

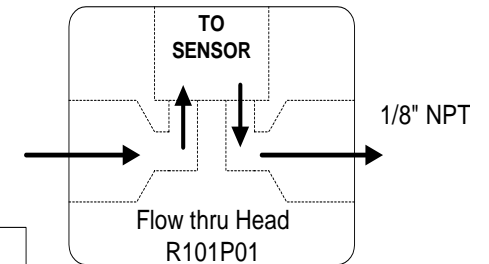
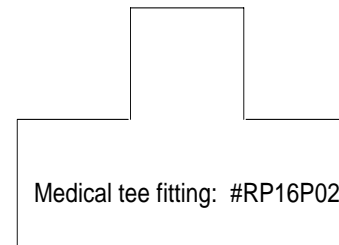
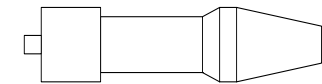

Maintenance and Disposal

The *HANDI™+* analyzer requires little maintenance. For best performance and accuracy, the *HANDI™+* should be calibrated on a frequent basis. For general use, it is recommended the *HANDI™+* be calibrated once a month on a known source of oxygen such as clean dry (compressed) air. Reference the calibration section in this manual for more details.

If the unit becomes wet, it should be dried off immediately with a soft dry towel. The display may indicate low concentrations of oxygen if the sample port of the sensor becomes wet. In this case, remove the barbed adapter and thoroughly dry inside and out with a soft dry towel or cotton applicator tip. Additionally, dry the face of the sensor with a cotton applicator tip and allow to air dry for one half-hour (or until the oxygen display returns to normal). Exposure of the *HANDI™+* to water or extremely high RH may result in shortened life or cause the electronic circuit or battery to fail.

Disposal: Please note the materials of construction for proper disposal. The material of the *HANDI™+* housing is a polycarbonate and ABS blend. The sensing portion of the *HANDI™+* contains lead and acetic acid. The *HANDI™+* contains a printed circuit board and a Lithium Battery.



WARNING: The *HANDI™+* should be disposed of properly in accordance with local regulations. Do not incinerate or expose the *HANDI™+* to flame or high temperatures.

General Specifications

Sensor Type:	Maxtec® MAX-250 galvanic cell w/ Temperature Compensation (Non-Replaceable)
Sensor Type:	Extra-Life Oxygen Sensor, galvanic cell type.
Measurement Range:	0.0 – 100.0% oxygen (gas).
Resolution/ Display:	0.1% - The three digit LCD indicates values between 0.0 – 99.9% oxygen. Over range indicated by one decimal point on display located after the first digit.
Display:	The three digit LCD indicates values between 0.0 – 99.9% oxygen.
Response Time:	< 15 seconds for 90% step change. (at 23°C)
Accuracy: @ 15° to 40°C	± 1 % of full scale at constant temperature, R.H. and pressure when calibrated at full scale. + 3% actual oxygen level over full operating temperature.
Power:	Powered by one internal, non-replaceable, lithium battery, CR2450. Power on push button automatically shuts off after 80 seconds time-out. Electronics rated general purpose; not for use in hazardous areas or for use with flammable gases.
Battery Life:	Approx. 1850 hours (74,000 cycles).
Sample Port	M-16 x 1 thread with barbed tubing adapter.
Operating Temperature:	15° to 40°C
Storage Temperature:	-15° to 50°C
Expected Storage Life:	Two months. Special freshness seal on sensor.
Operating Pressure:	Atmospheric pressure to 3psig.
Environmental:	General purpose housing equivalent to NEMA 1. The <i>HANDI™+</i> is not waterproof. 0 - 95% RH, non-condensing.
Warranty:	Twenty-four months in normal operating conditions.
Weight:	Approx. 60 grams

Introduction

Intended Use: The *HANDI™+* is a flexible tool, which is ideal for many applications. Compact and easy to operate, the *HANDI™+* can quickly monitor oxygen deficiency in ambient air or check process gas streams.

The *HANDI™+* features the model MAX-250 oxygen sensor that offers superior performance over conventional sensors. Based on a *weak acid* electrolyte, the MAX-250 is unaffected by CO₂ or other combustion gases. Additionally, the MAX-250 sensor offers extra life and excellent stability.

The sensing port of the *HANDI™+* is threaded to adapt to a wide variety of sampling accessories. With the barbed fitting, the *HANDI™+* can be quickly connected to a flexible tube for checking nitrogen or oxygen sources. With the flow through head accessory, the *HANDI™+* can be connected to process gas streams for a quick check of oxygen.

WARNING! For Your Safety:

- The *HANDI™+* is not rated intrinsically safe nor is it designed for use in areas where flammable vapors are present.
- This device does not contain automatic barometric pressure compensation.
- Do not use near any type of flame or flammable/explosive substances, vapors or atmosphere.
- **The *HANDI™+* is a verification tool and should not be used to control the gas blending or process control applications.**

Calibration Errors and Error Codes

The *HANDI™+* analyzers have a self test feature built into the software to detect faulty calibrations, oxygen sensor failures, and low operating voltage. These are listed below, and include possible actions to take, if an error code occurs.

E02: No sensor attached

Open unit and disconnect and reconnect sensor. Unit should perform an auto calibration and should read 20.9%. If not, contact Customer Service for possible sensor replacement.

E03: No valid calibration data available

Make sure unit has reached thermal equilibrium. Press and hold the Calibration Button for three seconds to manually force a new calibration.

E04: Battery below minimum operating voltage

Contact Customer Service for possible battery replacement.

CAL Err St: O2 Sensor reading not stable

Wait for displayed oxygen reading to stabilize, when calibrating the device at 100% oxygen.

Wait for unit to reach thermal equilibrium (Please note that this can take up to one half hour, if the device is stored in temperatures outside the specified operating temperature range).

CAL Err lo: Sensor voltage too low

Press and hold the Calibration Button for three seconds to manually force a new calibration. If unit repeats this error more than three times, contact Customer Service for possible sensor replacement.

CAL Err hi: Sensor voltage too high

Press and hold the Calibration Button for three seconds to manually force a new calibration. If unit repeats this error more than three times, contact Customer Service for possible sensor replacement.

CAL Err Bat: Battery voltage too low to recalibrate

Contact Customer Service for possible battery replacement.

Calibration

To simplify operation the Handi™+ Analyzer automatically determines the calibration gas being used as compressed air (20.9%) or high grade (100%).

For best performance and accuracy, the *HANDI™+* should be calibrated on a frequent basis. It is preferable to calibrate each day it will be used or at least once a month on a known source of oxygen. Clean, dry compressed air is a suitable cal gas.

Clean dry air typically contains approximately 20.9% oxygen. Expose the *HANDI™+* to air (compressed or ambient) and push the "CAL" button. The display will indicate the concentration of oxygen of the Calibration gas. It is recommended that the calibration gas be controlled to a pressure and flow rate equivalent to the measured gas. This may be accomplished by using the same gas sampling apparatus for calibration as for measuring in the intended application. For example, if the *HANDI™+* is used to check a nitrogen gas line, use the same sampling setup when calibrating. If the intended use is for checking room air, then calibrate the *HANDI™+* on clean ambient air (20.9% Oxygen). After adjusting the display to 20.9%, the *HANDI™+* is now calibrated and may be used to verify oxygen concentrations.

Always recalibrate the *HANDI™+* if the point of use elevation has changed by 500 feet. If unable to adjust the calibration pot so the display correctly indicates the value of the calibration gas, the *HANDI™+* has probably expired. If still within the warranty period, the unit should be returned to the factory for evaluation.

Introduction continued

CAUTION! For Your Safety:

- Read the manual in its entirety before attempting use.
- Always use protective eyewear and observe proper safety procedures when working with pressurized gases.
- Always assure the pressure of gas entering the *HANDI™+* is 3psig or less.
- Always calibrate the *HANDI™+* at an equivalent pressure and flow rate to the measured gas.
- Always calibrate the *HANDI™+* whenever the point of use elevation changes more than 500 feet (i.e.: Mexico City vs. San Diego,...).
- Dispose of the *HANDI™+* properly when it has expired.
- Ensure the protective freshness seal has been removed from the sensing port before use.
- Ensure the *HANDI™+* has been properly calibrated before use.
- If the *HANDI™+* display goes blank immediately after the on button is pushed, or the *HANDI™+* will not properly calibrate, the unit has expired. Do not use, dispose of properly.
- The display is not valid when in Over Range Mode. Recalibrate the *HANDI™+* and observe the proper operating procedure.
- Never immerse the *HANDI™+* or expose it to high humidity or moisture. It is not watertight.
- Never expose the *HANDI™+* to high temperatures.
- Never expose the *HANDI™+* directly to unregulated gas lines, cylinder gas, ... These may contain high gas pressures which may cause the *HANDI™+* to rupture.
- There are no internal user-serviceable parts in the *HANDI™+*.

Operation

General: The plastic freshness seal on the sensing port should be removed and discarded when you are ready to use the *HANDI™+* for the first time. This seal ensured freshness of the *HANDI™+* during shipping and storage. Once the seal is removed, you should expect to obtain the normal life from the *HANDI™+*. Included in the kit you will find the barbed adapter, which will screw onto the sensing port.

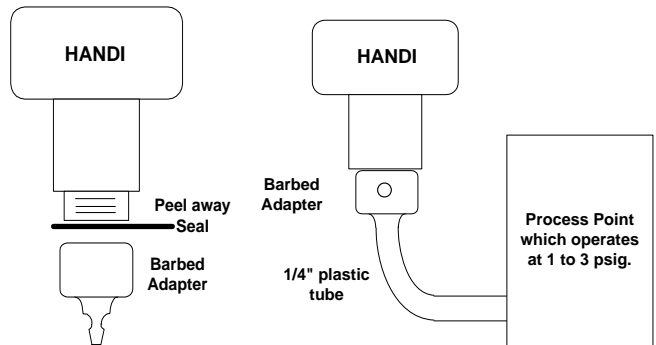

Using the Barbed Adapter: The *HANDI™+* is supplied with a 1/4" barbed adapter and short length of flexible 1/4" tubing. The tubing can be connected to process points using an equivalent barbed fitting. Gas from the process point (up to 3 psig) will be directed to the *HANDI™+* and exhaust through a small vent hole on the side of the barbed adapter. Allow some gas to pass through the barbed adapter and then observe the concentration of oxygen displayed. Please note the wetted parts of the *HANDI™+* are manufactured of CPVC. The barbed adapter is manufactured of ABS. Avoid process gases, which may attack these materials and cause shortened life. Maxtec also offers barbed fittings as an accessory for connection at the process point.

Operation continued

Working with High Pressures: The *HANDI™+* should never be connected to pressures greater than 3 psig. This could cause major failure of the sensing mechanism and may also cause the *HANDI™+* housing to rupture. The sample pressure must always be regulated down to the working pressure of the *HANDI™+* (0-3 psig). If you wish to measure the pressure directly at the high-pressure source, a suitable pressure regulator is required. The regulator must bring the gas entering the *HANDI™+* to 0-3 psig.

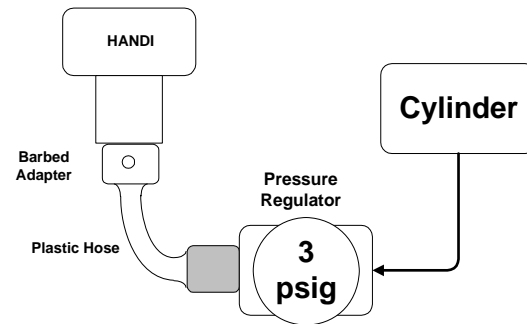

Measuring Room Air: The *HANDI™+* may be used to measure ambient air in cases where oxygen deficiency may be a concern. The barbed adapter supplied with the *HANDI™+* may slow down the response time when measuring room air. For this reason, it is important to unscrew and remove the Barbed Adapter from the *HANDI™+*. The *HANDI™+* is now ready to measure ambient air. Calibration on air known to be 20.9% should be performed before room air measurements.

It is also important to note the *HANDI™+* is not rated intrinsically safe nor is it designed for use in areas where flammable vapors are present.